

# OPERATING MANUAL

## PISTON PRESSURE SWITCH

DS-1\*\* / DS-3\*\* / DS-4\*\* / DS-5\*\*





**HYDROPA®** is a registered trademark of HYDROPA Hydraulische Erzeugnisse GmbH & Cie. KG.

**Contents**

<b>1</b>	<b>General information .....</b>	<b>3</b>
1.1	For operating personnel .....	3
1.2	Liability.....	3
1.3	For improved understanding of this manual .....	3
<b>2</b>	<b>Safety .....</b>	<b>4</b>
2.1	Correct use .....	4
2.2	Qualifications of personnel .....	4
2.3	Basic safety instructions .....	4
2.3.1	General information .....	4
2.3.2	During installation .....	4
2.3.3	Instructions relating to electrical connection.....	5
2.3.4	Maintenance .....	5
2.3.5	Cleaning.....	5
2.3.6	Instructions relating to environmental damage.....	5
2.3.7	Disposal .....	5
<b>3</b>	<b>Structure and function .....</b>	<b>6</b>
3.1	Structure .....	6
3.2	Function .....	6
3.3	Adjusting elements .....	6
3.4	Rating plate.....	7
<b>4</b>	<b>Transportation and storage.....</b>	<b>8</b>
4.1	Transportation.....	8
4.1.1	Instructions relating to transportation .....	8
4.1.2	Dimensional and weight specifications.....	8
4.2	Storage .....	8
<b>5</b>	<b>Technical data.....</b>	<b>9</b>
<b>6</b>	<b>Installation.....</b>	<b>10</b>
6.1	General information .....	10
6.2	Prior to installation .....	10
6.2.1	Required installation material and auxiliary equipment .....	10
6.2.2	Required tools.....	10
6.3	Installing the pressure switch .....	10
6.3.1	Standard G1/4" internal thread version (DS-3** / DS-4** series).....	11
6.3.2	Standard G1/4" internal thread version (DS-1** / DS-5** series).....	11
6.3.3	Flange version .....	11
6.3.4	Flange version with intermediate plate (PZ-***) .....	12
6.3.5	Flange version with 90° elbow connection plate .....	12
6.3.6	Switch panel installation version .....	12
6.4	Electrical connection.....	13
6.4.1	Connecting the pressure switch .....	13
6.4.2	Terminal assignment .....	13
6.4.3	Earthing the pressure switch .....	13
6.4.4	Cable socket.....	14
6.4.5	Contact protection .....	14

<b>7</b>	<b>Commissioning .....</b>	<b>15</b>
7.1	Operation .....	15
7.1.1	Switching point setting (by manufacturer, only on request) .....	15
7.1.2	Switching point setting for rising pressure (by customer) .....	15
7.1.3	Switching point setting for failing pressure (by customer) .....	15
<b>8</b>	<b>Dismantling, replacement and decommissioning .....</b>	<b>16</b>
8.1	Dismantling .....	16
8.2	Replacement .....	16
8.3	Spare parts.....	16
8.4	Decommissioning.....	16
8.5	Disposal .....	16
8.6	Troubleshooting .....	17
<b>9</b>	<b>EC Declaration of Conformity .....</b>	<b>17</b>

## 1 General information

### 1.1 For operating personnel

This operating manual provides you with information on the safety, structure, function and operation of the pressure switch.

If heeded carefully, the manual will ensure long and reliable operation free of malfunctions.

#### Applicable documents

- EC Declaration of Conformity (see appendix)





### 1.2 Liability

Any liability on the part of **HYDROPA**<sup>®</sup> with regard to defects and liability claims is rendered void in the event of damages resulting from incorrect use and unilateral interventions not foreseen in this operating manual.

Please refer to the **HYDROPA**<sup>®</sup> General Business Terms and Conditions for details of liability for material defects.

Unilateral structural changes to the pressure switch are not permitted for reasons of safety.

### 1.3 For improved understanding of this manual

DANGER	
	This hazard warning label indicates an immediate and major hazard which will definitely result in severe injuries or even fatalities if the hazard is not avoided.
WARNING	
	This hazard warning label indicates a potential hazard which can result in severe injuries or even fatalities if the hazard is not avoided.
CAUTION	
	This hazard warning label indicates a potentially hazardous situation which can result in medium or light injuries or material damage if it is not avoided.
NOTE	
	This label indicates helpful information.

(Cross-references are indicated with *italics*.)

## 2 Safety

### 2.1 Correct use

Adhere to the performance limits specified in the technical data.

Correct use also requires that you have read this manual completely, particularly chapter “2.3 *Basic safety instructions*”, and that you have understood everything therein. Please contact our sales department if in any doubt.

Any use other than or beyond this is considered as incorrect and is, consequently, expressly prohibited. The owner or operator bears responsibility for all damage resulting from incorrect use.

This pressure switch is not suitable for operation in a potentially-explosive environment.

Correct use also includes:

- the heeding of all instructions in the operating manual
- the heeding of all mandatory, prohibition and warning signs

### 2.2 Qualifications of personnel

Commissioning requires fundamental electrical and hydraulic knowledge and knowledge of associated technical terminology. In order to ensure operational liability, these tasks should therefore only be entrusted to a suitable skilled worker or an instructed person under the supervision of a skilled worker who has received regular training and instruction.

A skilled worker is someone who, on the basis of his technical training, know-how and experience and knowledge of pertinent regulations, can evaluate the work entrusted to him, identify potential hazards and take suitable safety measures. A skilled worker should adhere to relevant specific technical rules.

### 2.3 Basic safety instructions

#### 2.3.1 General information

Changes to the hazard potential may arise as a result of the interaction which occurs following installation of the pressure switch. Therefore, this operating manual does not replace the operating instructions for the plant in which the pressure switch is installed. It is imperative that the superordinate operating manual be read and understood.

The safety instructions are designed to avoid injuries and damage to the plant and environment. All operators are obliged to read these safety instructions and heed them at all times.

- The pressure switch should only be used in a technically flawless condition.
- Modifications or conversions of the pressure switch should be avoided, as these render the EC Declaration of Conformity and operating permit null and void.
- The pressure switch should only be used within the performance range specified in the technical data for the respective pressure switch.
- The pressure switch is not suitable for use in a potentially explosive environment.
- When exchanging defective components, these should only be replaced with original parts with the same electrical and mechanical data, as safety and the function can otherwise not be maintained.
- All safety equipment, fixing elements and electrical connections, cables and lines should be inspected regularly to ensure that they are in a flawless condition.

#### 2.3.2 During installation

- The relevant plant section should always be relieved of pressure and de-energized prior to installing/dismantling the pressure switch.
- Secure the plant section against reactivation.
- Cables and lines should be laid in a manner that prevents them being damaged (e.g. heat, cold, ozone, etc.).
- Ensure prior to commissioning that all connections are correctly fitted and undamaged to prevent any liquid emerging.

### 2.3.3 Instructions relating to electrical connection

- Electrical work should only be realised by a trained skilled electrical worker. According to German safety regulations (BGV A2), a skilled electrical worker is someone who, on the basis of his technical training, know-how and experience and his knowledge of pertinent regulations, can evaluate the work entrusted to him and identify potential hazards.

### 2.3.4 Maintenance

- The pressure switch does not require any maintenance. However, we recommend that the set switching points should be checked at regular intervals.
- Operation should be ceased immediately if the pressure switch fails to function in an orderly manner.

### 2.3.5 Cleaning

- Close all openings with suitable safety devices to ensure that no cleaning media or other contaminants can penetrate the system.
- Never use solvents or aggressive cleaning agents. Only use a mildly damp cloth made of non-fibrous fabric for cleaning the pressure switch. Only use water for this purpose and, where appropriate, a mild cleaning agent.
- Do not use high-pressure cleaners for cleaning.

### 2.3.6 Instructions relating to environmental damage

- Following decommissioning, the pressure switch should be recycled or disposed of in accordance with legal regulations. Legal regulations should be heeded during disposal.

### 2.3.7 Disposal

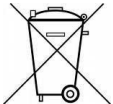
DISPOSAL	
	<p>Dispose of the pressure switch in a professional manner in compliance with the national regulations of your country.</p> <p>The component should not be disposed of with household waste.</p>

### 3 Structure and function

#### 3.1 Structure

The piston pressure switch fundamentally consists of the following components:

- (1) Housing
- (2) Microswitch
- (3) Adjusting element
- (4) Compression spring
- (5) Spring plate
- (6) Piston
- (7) Nozzle

#### 3.2 Function

The pressure switch functions on the basis of the piston-spring principle. The microswitch (2) is actuated if the pressure lies below the configured value. The piston (6) acts against the spring plate (5) when pressure builds up. This braces itself against the continuously-adjustable compression spring (4). The piston (6) transfers the force onto the spring plate (5) when the configured pressure is reached on the nozzle (7), enabling the microswitch (2) and triggering an electrical signal. The pressure to be monitored is determined by the preload tension of the spring (4). Adjustment is achieved by turning the adjusting element (3). Anticlockwise rotation reduces the switching pressure, while turning in a clockwise direction increases the switching pressure. The adjusting element (3) is fixed with the securing screw and fixing cover. A mechanical stop prevents the compression spring (4) from seizing due to excessive turning.

#### 3.3 Adjusting elements

Three adjusting elements can be selected for setting the pressure.



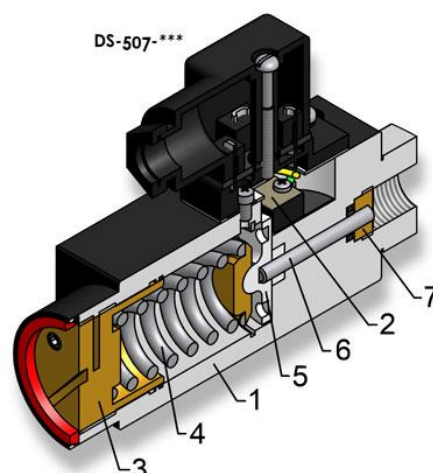
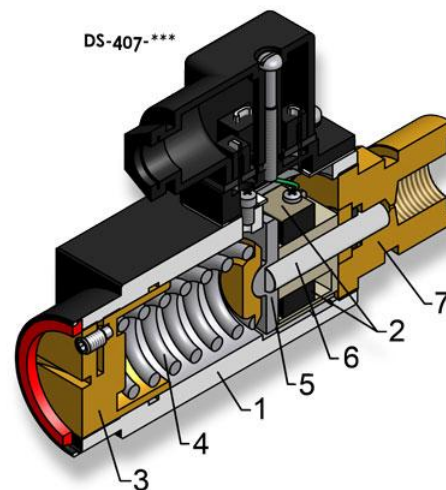
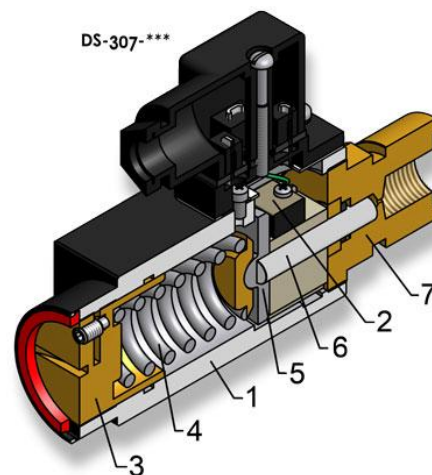
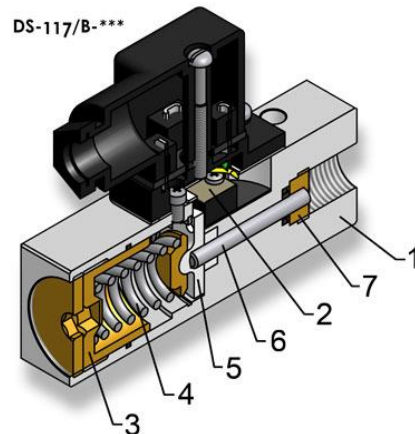



- The adjusting screw cover
- The adjusting knurl with scale
- The lockable adjusting knurl with scale  
(except for DS-1\*\* series)

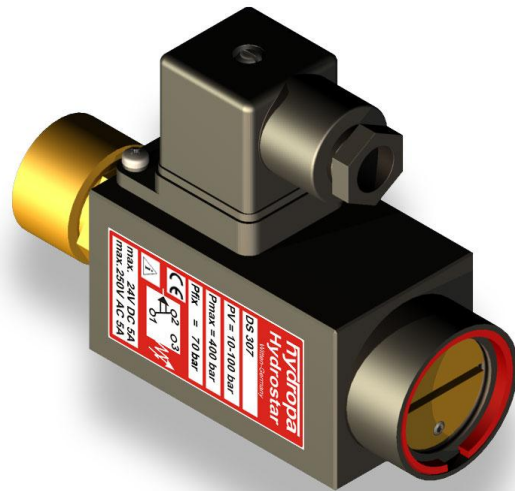
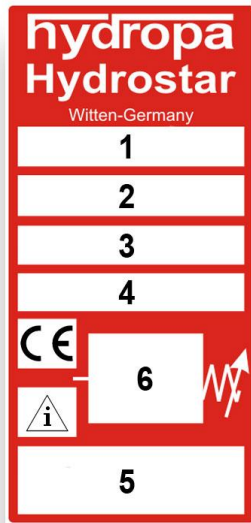

### 3.4 Rating plate

The rating plate is affixed to the pressure switch housing.



Field no.	Field designation	Customer specifications				
1	Type key	e.g.: DS 307				
2	Switching pressure range	e.g.: PV = 10-100 bar				
3	Max. operating pressure	e.g.: Pmax = 400 bar				
4	Pressure default	e.g.: Pfix = 70 bar				
5	Electrical connection	e.g.: max. 24V DC 5A max. 250V AC 5A				
6	Switch symbol	e.g.: <table border="1" style="display: inline-table; vertical-align: middle;"> <tr> <td style="text-align: center;">DS 302</td> <td style="text-align: center;">DS 307</td> </tr> <tr> <td></td> <td></td> </tr> </table>	DS 302	DS 307		
DS 302	DS 307					
						

#### NOTE



Please state the order number in the event of malfunctions, when ordering spare parts and prior to calling our customer service department.

## 4 Transportation and storage

### 4.1 Transportation

#### 4.1.1 Instructions relating to transportation

General safety instructions should be observed during transportation.

#### 4.1.2 Dimensional and weight specifications

Dimensional and weight specifications can be found in the technical data for the respective pressure switch.

#### CAUTION



Impacting and severe vibration should be avoided where possible during transportation.

### 4.2 Storage

The pressure switch can be stored at the factory for up to six months in compliance with the following criteria:

- Do not store in the open. Always store under a roof or in a well-ventilated room.
- Protect against rising damp: store in a shelf system or on a wooden pallet.
- Cover with film to protect against dust and dirt.
- Following opening, transportation packaging should be closed again correctly for storage.

#### NOTE



**HYDROPA**<sup>®</sup> must be consulted in the case of storage for periods longer than six months or sea transportation.

## 5 Technical data

Technical data is contained in the data sheet for the respective pressure switch and on the rating plate.

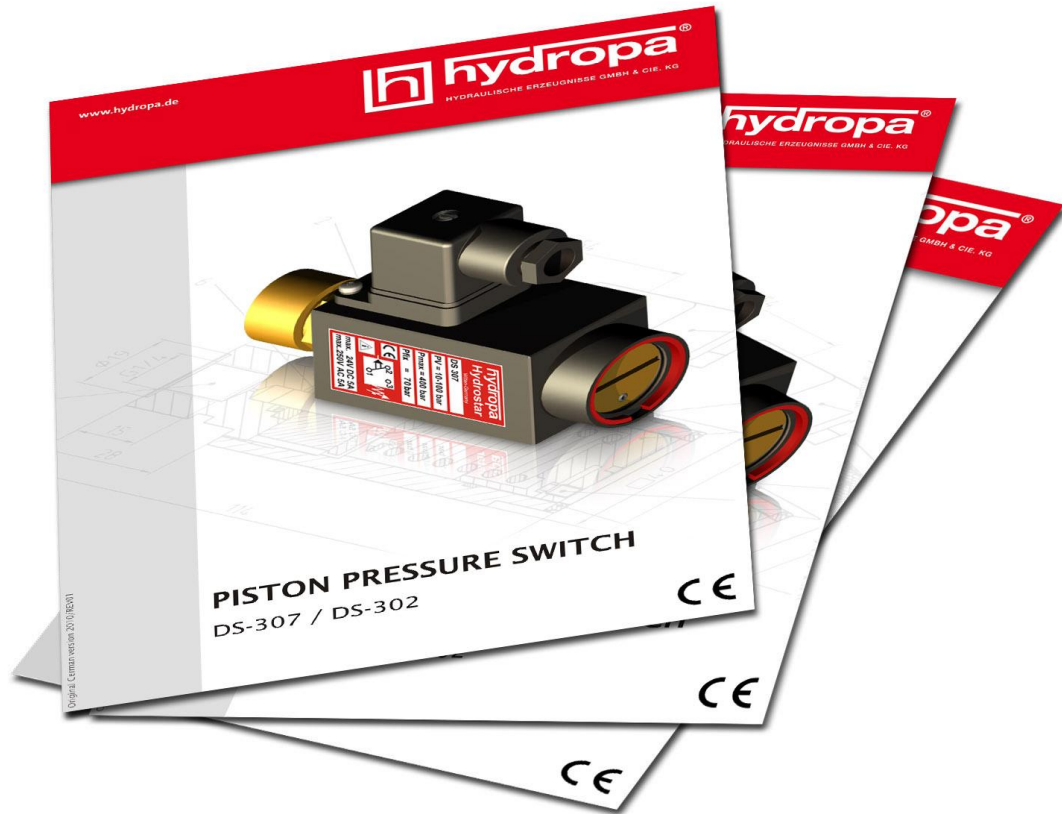

## 6 Installation

### 6.1 General information

#### DANGER of injury and material and environmental damage



It is imperative that the safety instructions in chapter "2 Safety" on page 4 are observed.

### 6.2 Prior to installation

- Extreme cleanliness should be ensured, as dirt leads to malfunctions and can impair the reliable function of the components.
- Conduct a visual inspection for any transportation damage and dirt.

#### 6.2.1 Required installation material and auxiliary equipment

Fixing hole (diameter in mm)	Hexagonal screws pursuant to DIN 933 (A2 – 70)	Number	Maximum tightening torque in Nm <sup>1)</sup>
Ø5.5	M5	4/2	4.2

<sup>1)</sup> A torque spanner with a tolerance  $\leq 10\%$  should be used for tightening. The specified tightening torques can be understood as extremely rough and non-binding reference values. See VDI 2230 for the calculation of the tightening torque. Coefficient of friction  $\mu_{\text{total}} = 0.14$  lightly oiled.

#### 6.2.2 Required tools

Only commercially available tools and torque spanners are required to install the pressure switch.

### 6.3 Installing the pressure switch

#### DANGER of injury and material damage



The relevant plant part should always be relieved of pressure and de-energized prior to installing/dismantling the pressure switch.

Use of the pressure switch is only permitted in plants in which the max. operating pressure  $P_{\text{max}}$  is not exceeded (see technical data or rating plate).

#### WARNING of risk of injury and material damage



Exceeding of the max. operating pressure  $P_{\text{max}}$  through pressure peaks and pressure surges and the exceeding of temperature limit values lead to consequences ranging from behavioural changes to damage.

#### NOTE



The pressure switch should be installed in a low vibration environment and protected against pressure surges to increase the service life.

All dimensions relevant to installation and other information can be found in the technical data for the respective pressure switch.

### 6.3.1 Standard G1/4" internal thread version (DS-3\*\* / DS-4\*\* series)

The standard G1/4" internal thread version can be mounted directly on a pipe connection. Ensure that the installation spanner (A/F 27) is only applied to the threaded flange during installation (see Fig. 1). Fixing options are provided by two M5x10mm deep threaded holes located opposite the unit plug (see Fig. 2) or Ø5.5mm through-holes in conjunction with an adapter plate (ordered separately) (see Fig. 3).

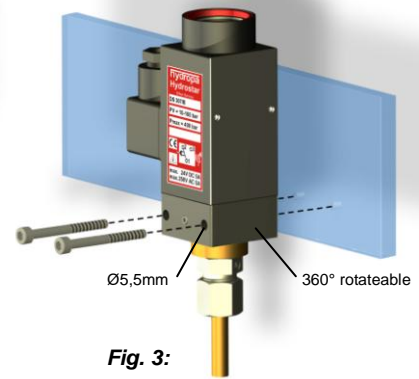
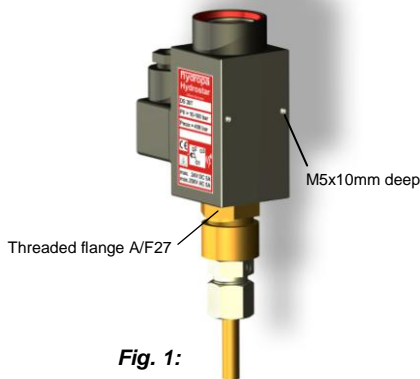

### 6.3.2 Standard G1/4" internal thread version (DS-1\*\* / DS-5\*\* series)

The installation spanner (A/F 24) should also only be applied to the threaded flange when installing the DS-5\*\* series (see Fig. 4). The installation spanner (A/F 30) should be applied directly on the housing when installing the DS-1\*\* series. Fixing options are provided by two Ø5.3mm through-holes (see Fig. 5).

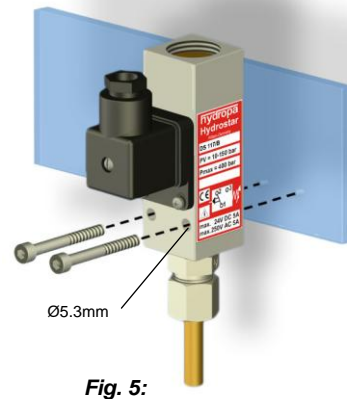

### 6.3.3 Flange version

Fix the pressure switch to the flange provided using two or four screws. Two screws are sufficient in the case of low pressure ranges and normal operating conditions. Ensure that the o-ring is not missing or damaged during installation.

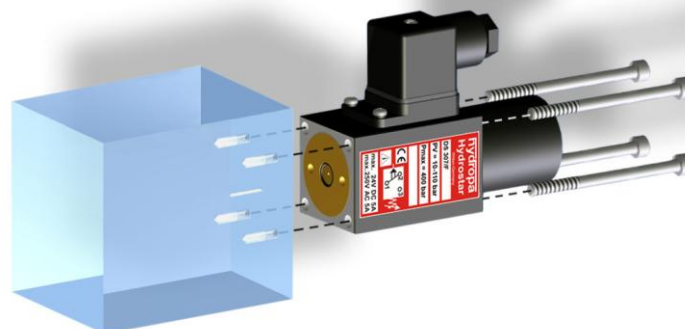

### 6.3.4 Flange version with intermediate plate (PZ-\*\*\*)

The flange version can be used in conjunction with an intermediate plate (ordered separately) for NG6 (PZ-6/1/\*\*) or NG10 (PZ-10/\*\*) sandwich arrangements.

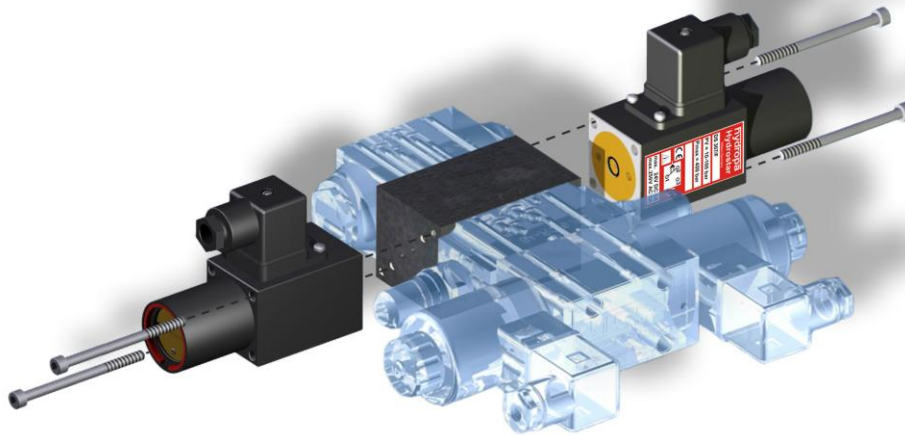

### 6.3.5 Flange version with 90° elbow connection plate

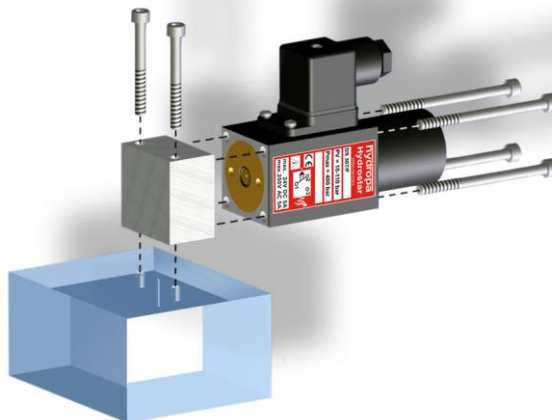

### 6.3.6 Panel installation version

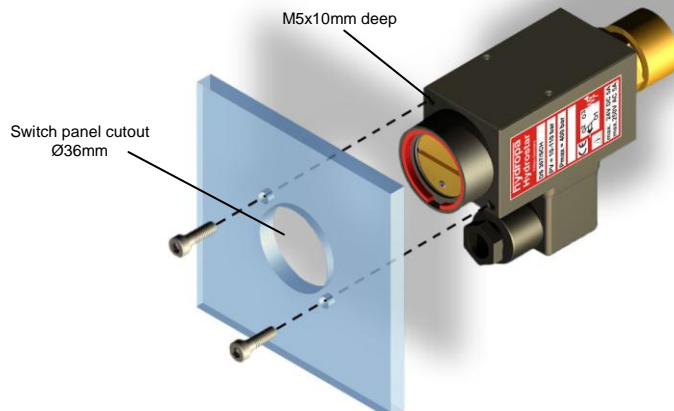

## 6.4 Electrical connection

### DANGER of hazardous electrical voltage!



Electrical work should be entrusted exclusively to a trained skilled electrical worker.

### 6.4.1 Connecting the pressure switch

The electrical connection should be established by a skilled electrical engineering worker in compliance with prevailing safety and accident prevention regulations. Pertinent installation and operating regulations (e.g. for cable cross-sections, fuse protection, protective earth connection) should be observed. Power supply conforming to EN 50178, SELV, PELV. Ensure when introducing and screwing the connection cable that cable conductors are connected in accordance with regulations to connection terminals. Ensure that the connection cable is not bent to avoid short circuiting and interruptions.

Observe the 5 electrical safety rules:

#### 5 Safety Rules

- Disconnect
- Secure against reactivation
- Ensure that the unit is de-energized
- Earth and short circuit
- Cover or cordon off adjacent energized parts.

### 6.4.2 Terminal assignment

The pressure switch is delivered from the factory with a cable socket conforming to EN 175301-803, model type A. Please refer to the technical data for the respective pressure switch for further connection options.

1. Connection diagram DS-\*\*7 (Standard)

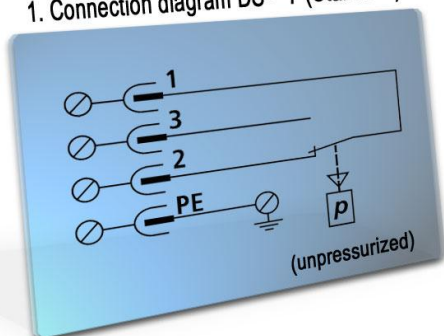

Terminals 1-2: contact breaks if pressure rises  
 Terminals 1-3: contact makes if pressure rises

2. Connection diagram DS-\*\*2

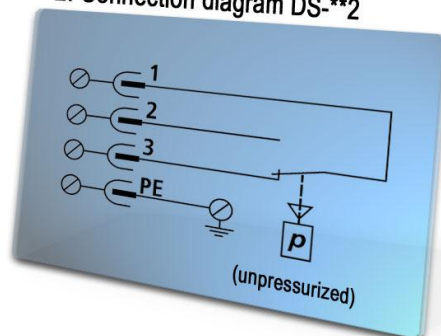





Terminals 1-3: contact breaks if pressure rises  
 Terminals 1-2: contact makes if pressure rises

### 6.4.3 Earthing the pressure switch

Ensure that the pressure switch is adequately earthed:

- The protective earth (PE ≡) should be connected in compliance with regulations for the electrical connection.

### 6.4.4 Cable socket

	<p>Cable socket conforming to EN 175301-803, model type A, PG9</p> <ul style="list-style-type: none"> <li>- for cable diameter Ø6-8mm</li> <li>- torque for fixing screw (M3) 0.4Nm</li> </ul>	
	<p>Cable socket conforming to EN 175301-803, model type A, PG11</p> <ul style="list-style-type: none"> <li>- for cable diameter Ø8-10mm</li> <li>- torque for fixing screw (M3) 0.4Nm</li> </ul>	
	<p>Cable socket with LED function display</p> <ul style="list-style-type: none"> <li>- for 12 to 220V AC/DC connection voltages</li> <li>- ordering add-on DS-307/LED34-350</li> <li>- torque for fixing screw (M3) 0.4Nm</li> </ul>	
	<p>Cable socket with LED function display</p> <ul style="list-style-type: none"> <li>- with LED/lamps insert for 24V, 120V or 220V</li> <li>- ordering add-on DS-307/L-MP24-350 and DS-307/L-MP220-350</li> <li>- torque for fixing screw (M3) 0.4Nm</li> </ul>	
	<p>M12x1 cable socket, 4-pole</p> <ul style="list-style-type: none"> <li>- only available on request</li> <li>- axial or 90° angled version</li> </ul>	

### 6.4.5 Contact protection

The microswitches used are designed for operation with both direct and alternating voltage. In order to avoid damage to the contacts caused by any inductive, capacitive and lamp loads which occur, a appropriate protective circuit (spark suppression or current limitation) should be provided to suit the operational case in question.

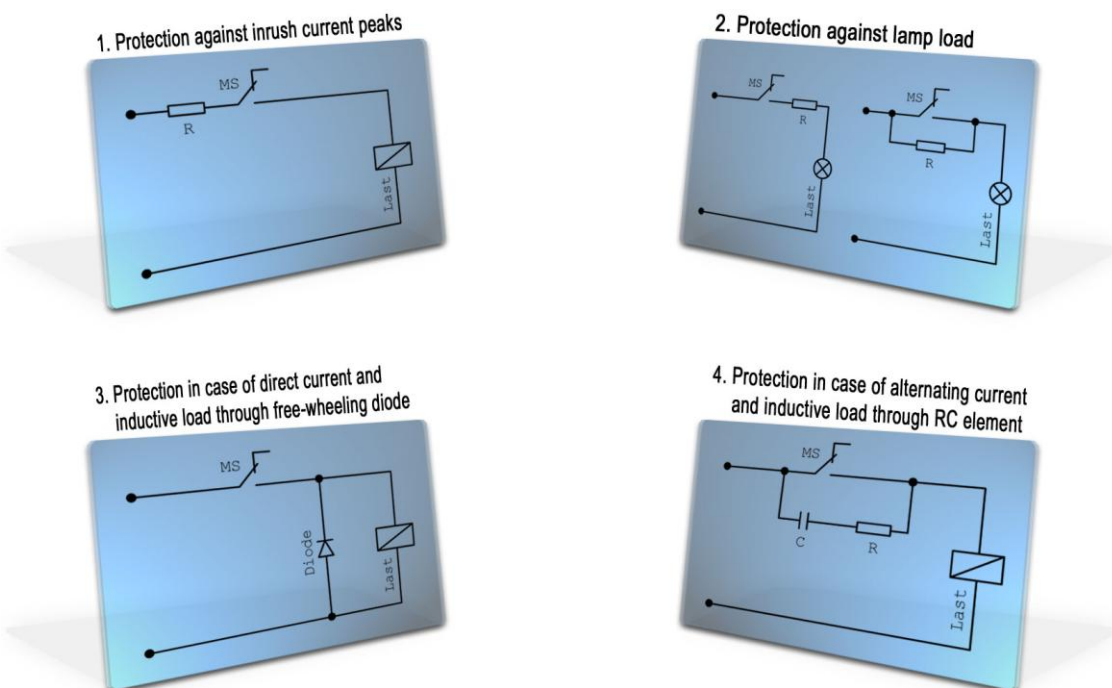

## 7 Commissioning

### WARNING of risk of injury and material damage



The correct pressure switch installation should be inspected prior to initial commissioning.

The pressure switch should only be commissioned by trained skilled personnel who have read and understood the operating manual.

The pressure switch should only be operated within specifications (please compare the technical data in the data sheet in this respect).

### 7.1 Operation

#### 7.1.1 Switching point setting (by manufacturer, only on request)

The switching points are set by the manufacturer to the values specified in the order and stipulated on the rating plate with Pfix.

#### 7.1.2 Switching point setting for rising pressure (by customer)

1. Loosen the fixing screw/fixing cover with the aid of a hexagonal socket spanner.
2. Regulate the system pressure to a value clearly below the desired switching pressure.
3. Now increase the system pressure slowly and observe whether the microswitch triggers at the desired switching pressure. Correct if necessary with the aid of the adjusting element. Repeat steps 2 to 3 until the microswitch triggers at the desired switching pressure.
4. Then fix the fixing screw/fixing cover and check the switching pressure setting again. Readjustment may be necessary after fixing.

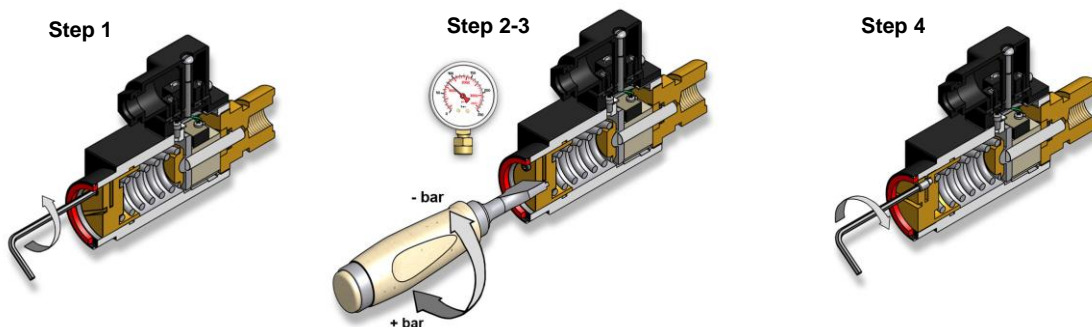

#### 7.1.3 Switching point setting for failing pressure (by customer)

1. Loosen the fixing screw/fixing cover with the aid of a hexagonal socket spanner.
2. Regulate the system pressure to a value clearly above the desired switching pressure, but only to the max. operating pressure of the respective pressure switch at the most.
3. Now lower the system pressure slowly and observe whether the microswitch triggers at the desired switching pressure. Correct if necessary with the aid of the adjusting element. Repeat steps 2 to 3 until the microswitch triggers at the desired switching pressure.
4. Then fix the fixing screw/fixing cover and check the switching pressure setting again. Readjustment may be necessary after fixing.

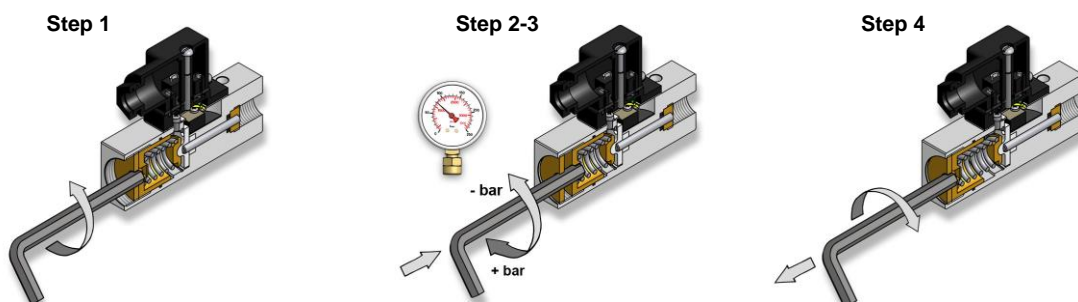

## 8 Dismantling, replacement and decommissioning

### 8.1 Dismantling

#### DANGER of injury and material and environmental damage



It is imperative that the safety instructions in chapter "2 Safety" on page 4 are observed.

The following points should be realised prior to dismantling for reasons of safety:

- Deactivate the pressure switch and disconnect from the power supply network.
- No cables, connections or components should be loosened as long as the plant is energized. Loads on the plant should be lowered in advance, pressure accumulators, etc. relieved of pressure, pumps deactivated and secured against reactivation. General safety regulations should be observed (see *chapter "2. Safety" on page 4*).

### 8.2 Replacement

The pressure switch to be used should exhibit the same parameters as the pressure switch to be replaced.

### 8.3 Spare parts

Spare parts can be ordered on the basis of the parts list or rating plate.

The order should be forwarded to the following address, stipulating the order number:

**HYDROPA®**  
**Därmannsbusch 4**  
**D-58456 Witten (Herbede)**

Telephone (0 23 02) 70 12-0

Fax (0 23 02) 70 12-47

Internet: [www.hydropa.de](http://www.hydropa.de)

E-mail: [info@hydropa.de](mailto:info@hydropa.de)

### 8.4 Decommissioning

The following should be observed when decommissioning the pressure switch:

- Dismantling work should only be entrusted to a trained skilled electrical worker (see *section "2.2 Qualifikation des Personals on page 4*);

### 8.5 Disposal

Thoughtless disposal of the pressure switch can lead to environmental pollution.

- Residues on the pressure switch can, depending on the medium used, pose a danger to skilled personnel and the environment. Appropriate safety measures should be taken where necessary and the pressure switch disposed of correctly.

#### DISPOSAL



Dispose of the pressure switch in a professional manner in compliance with the national regulations of your country.

The component should not be disposed of with household waste.

## 8.6 Troubleshooting

Error	Possible cause	Error detection / Remedy
No signal from pressure switch	No power supply	Check power supply (skilled electrical worker)
No signal from pressure switch, or pending signal does not drop off	Defective microswitch	Check with the aid of a measuring device whether a switching cycle occurs during pressure change between the contacts on the pressure switch (skilled electrical worker)
No signal from pressure switch, or pending signal does not drop off	Mechanical defect (e.g. piston)	Check with the aid of a measuring device whether a switching cycle occurs during pressure change between the contacts on the pressure switch (skilled electrical worker)
No signal from pressure switch, or pending signal does not drop off	Adjusting element unscrewed too far	Screw in the adjusting element somewhat and check the switching point
Switching point displacement	Material wear (compression spring)	Readjust the switching point (see chapter "7 Commissioning" on page 15)
Pressure switch oily	Internal leakage flows	Remove the pressure switch as described in chapter "8 Dismantling" and forward it for inspection
Pressure switch exhibits leaks on connection thread	Mechanical damage	Remove the pressure switch as described in chapter "8 Dismantling" and forward it for inspection

## 9 EC Declaration of Conformity

The unit delivered meets legal requirements. Directives, harmonised standards and documents applied are listed in the EC Declaration of Conformity valid for the product. The operational reliability and safety of the unit is also confirmed by the CE symbol on the rating plate

